

SUMMER
2020

The Official Publication of the Water Environment Association of Utah

DIGESTED news

Celebrating 50 Years of Clean Water

Can Wastewater Influent Be Used to Track the Spread of COVID-19?

Central Valley WRF
800 West Central Valley Road
Salt Lake City, Utah 84119
Address Service Requested

INSIDE:

COVID-19 Life for Operators ■ What Could Municipal Wastewater Sampling Tell About the Coronavirus Epidemic?



Discover the Cost-Effective Difference ACO Stormbrixx Makes For You.



Schoonover Case Study

The Schoonover Plumbing ACO Stormbrixx project was brought to Mountain Supply out of a need to find a cost-effective way to eliminate an on-site drainage pond, while staying in compliance with the current State of Utah Stormwater Requirements. In order to eliminate the pond, it was determined that an underground stormwater detention system would be necessary. Working with Mustang Design and ACO an appropriately sized below ground retention system was designed for the site that included two access and maintenance points. Once approved, the system was installed with on-site assistance from Mountainland Supply.

By using Stormbrixx the owner was able to eliminate the pond by detaining the stormwater under their parking lot in a Stormbrixx system. This system not only saved the owner from wasting land but created a structurally sound “modular vault” that will be able to be maintained for years to come. By retaining and infiltrating the storm water 100% on site the owner was able to eliminate the extra cost incurred by connecting to the city’s storm sewer system.



Call Your Mountainland Sales Rep.
for a FREE Site Evaluation and Solution!



PROVIDING SERVICE, SUPPORT AND SOLUTIONS



Planning

- Technical Support
- Preliminary Layout
- Budget Estimate
- Factory Tours
- Project Tours



Design

- Design Seminars
- Piping Profile
- Vacuum Station
- Standard Details
- Sample Specifications



Construction

- Installation Support
- Tightness Testing
- Line Start-up
- Station Start-up
- Initial Operation



Operation

- 24/7 Support
- Operator Training
- Parts and Repairs
- System Check-ups
- Maintenance Contracts

Conception to completion and beyond.

Airvac is more than a provider of vacuum sewer components. We provide cost-effective solutions to public works directors, engineers and developers for their wastewater collection needs. We are a company built with a core value of service and support. From planning, to design, to construction and operation, our team is there for you.

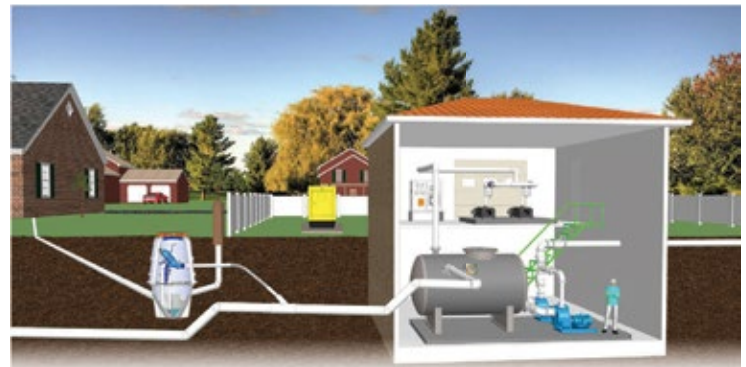

Contact us for a
free system layout and cost estimate.



Airvac

Aqseptence Group, Inc.
Vacuum Technology Systems
Phone +1 574 223 3980
info.airvac@aqseptence.com
www.aqseptence.com



NO LOWER BEARINGS, SPROCKETS, BUSHINGS OR GUIDES. NO PROBLEMS!

Capture more debris with no fouling or jamming. Lakeside's **Raptor® FalconRake® Bar Screen** features a trouble-free stainless steel chain link design and multiple rake heads to achieve continuous, highly efficient solids removal with low headloss. The energy saving drive system operates at variable speeds to ensure superior cleaning, and is easily accessible above the water surface. And, as with everything Lakeside manufactures, our heavy-duty design and all stainless steel construction is made to last even in the most severe conditions. Protect your downstream equipment with the **Raptor FalconRake Bar Screen**, Lakeside's proven, durable and cost-effective screen technology for rapid debris removal in municipal and industrial applications.

REPRESENTED LOCALLY BY:



Goble Sampson Associates
3500 South Main Street, Ste. 200
Salt Lake City, UT 84115
Office: 801-268-8790



Cleaner Water for a Brighter Future®

Speak to one of our experts at **630.837.5640**, email us at **sales@lakeside-equipment.com** or visit **lakeside-equipment.com** for more product information.



Raptor® Screening Products

- Fine Screen
- Micro Strainer
- Rotating Drum Screen
- Septage Acceptance Plant
- Septage Complete Plant
- Complete Plant
- Multi-Rake Bar Screen
- FalconRake® Bar Screen
- Rotary Strainer Screen
- Wash Press

WEAU
BOARD OF DIRECTORS
2020-2021

President
Chris Reilley
reilleyc@cvurf.org

President Elect
Trevor Lindley
tlindley@bruncald.com

Vice President
Sarah Ward
sarabward@utab.org

Treasurer
John Richardson
jrichardson@bruncald.com

Secretary
Chad Burrell
cburrell@sburd.org

Past President
Giles Demke
gedemke@orem.org

WEF Delegate
Sherry Sheffield
ssheffield@suvwater.com

WEF Delegate
Clint Rogers
clint.rogers@stantec.com

PWO Representative
Tyler Barfuss
tbarfuss@ndsd.org

PWO Representative Elect
Daniel Watts
djub56@yahoo.com

Director
Rob Jaterka
rob@magnawater.com

Director
Marianna Sochanska
msochanska@bruncald.com

Director
Jared Jenkins
jjenkins@goblesampson.com

Director
Gary Vance
gvance@jub.com

Editor
Bryan Mansell
mansellb@cvurf.org

Published by:



On behalf of the WEAU



Tel: 866-985-9780

Fax: 866-985-9799

www.kelmanonline.com

Managing Editor, **Scott Kelman**
and **Katie Woychyshyn**

Design/Layout, **Tracy Toutant**
Advertising Sales, **Kris Fillion**

Advertising Co-ordinator, **Stefanie Hagidiakow**



FEATURES

COVID-19 Life for Operators **19**
 Can Wastewater Influent Be Used to Track the Spread of COVID-19? **20**
 What Could Municipal Wastewater Sampling Tell About the Coronavirus Epidemic? **22**
 Flexible Operator Certification/Credentialing Requirements During COVID-19 Response **25**
 Revolutionary Technology Delivers Major Leak Reduction **27**
 Do the SDGs Apply to Me? A Resounding Yes! **29**
 Congratulations to WEAU Scholarship Recipients **33**



Departments

President's Message **7** Pretreatment **14**
 Editor's Message **9** Certification Training **17**
 PWO **11** Awards and Election Results **35**
 Collections **12** Advertisers' Index **38**

Available Online **DIGESTED news**



With print and electronic communication operating hand-in-hand, you can take advantage of the fact that *Digested News* magazine is available online in a highly interactive format.

A user-friendly, interactive Media Rich PDF format that includes:

1. Active hyper-links to all websites and emails contained in the publication
2. Active links to the specific stories from the front cover and contents page
3. Active links to advertiser websites from their ads

Only **PISTA**® Technology Delivers...
GRIT REMOVAL SYSTEM

95%

Grit Removal.

At All Flows.



All the Way from Chamber to Washing/Dewatering.

Exclusive Flat-Floor Baffled Vortex Design



Retrofit Solutions for 95% Removal



95% Removal Through All Grit Washing



There is only one grit removal system designed to remove 95% of grit down to 100 micron FOR ALL FLOWS experienced at WRRFs and treatment plants. While competing technologies derate efficiencies at peak flows, PISTA® hydraulic vortex grit removal systems consistently deliver in all conditions—all the way thru grit washing and dewatering—backed by third-party testing, not theory. Systems derating for storm events are not “advanced” — **only the baffled PISTA® holds stake to that claim.**



Represented Locally by: **Waterford Systems**

CALL 801-463-9900

EMAIL jeff.waterford@gmail.com



Smith & Loveless Inc.



Chris Reilley

What is Your Story?

WOW!!! Has the last several months been a strange ride or what? It probably feels to some like our world just turned upside down and to others like it came to a complete stop. Things have just changed. Depending on our circumstances, it has affected us all in some way. I know that some within our association have been able to work from home, while others have been stuck at home altogether. Some of our associates have had to work longer days and different schedules to keep things

“ With this change, we can grow. We're finding new ways to connect, help and serve each other.

moving forward in the broad scope of jobs within our industry. With the different components of critical infrastructure that is interwoven within our communities, we all serve with the great desire to help make a difference to protect our environment and the people we serve. Thank you! All of you, for everything you do.

I know that we all have a story or experience that make us who we are; and those stories are part of what defines us. These current circumstances are part of our stories and experiences. For me, I took a part time job 26 years ago as a parts runner just to help me get through college, until I could find a better job or at least one that

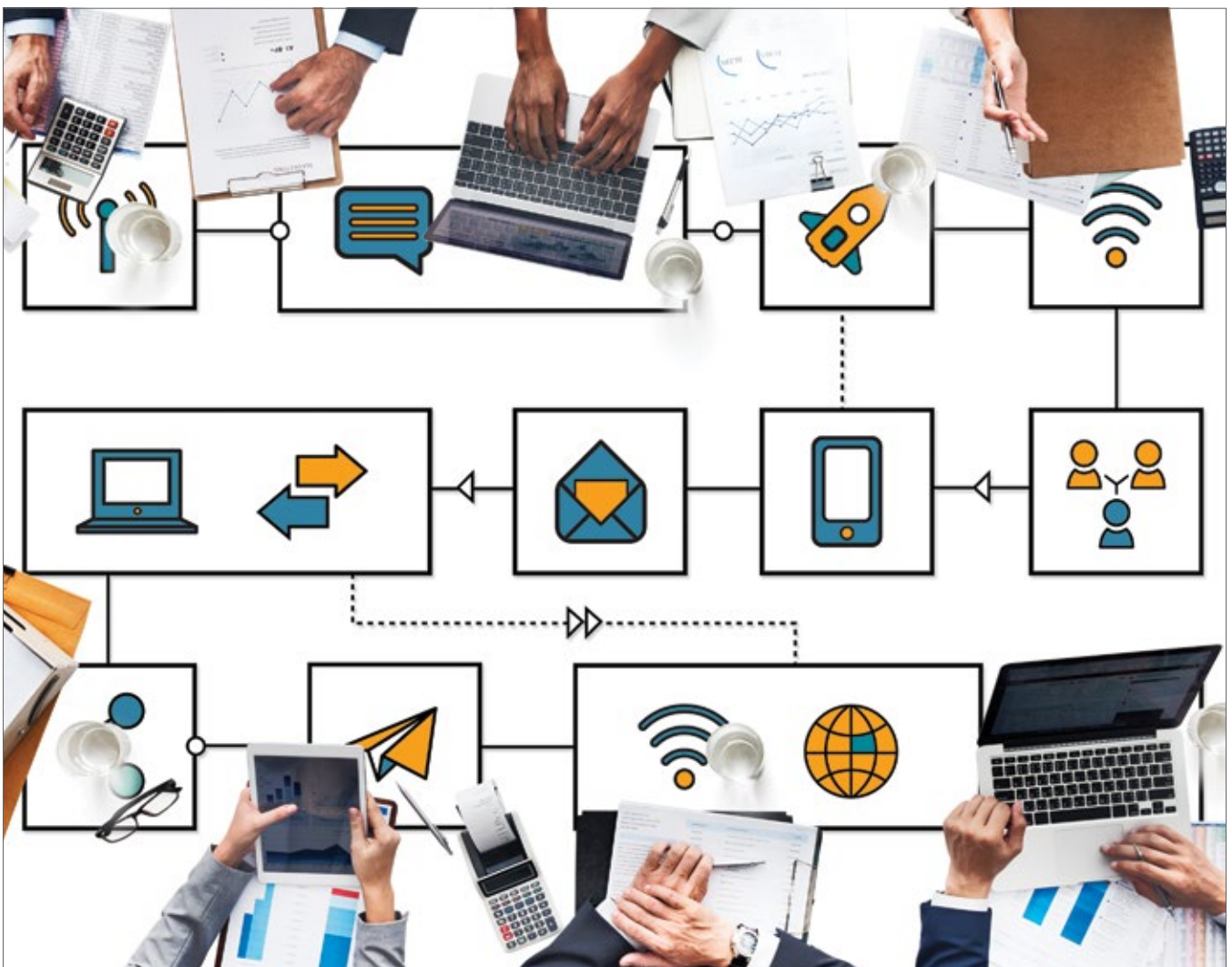

“ This is one of our many purposes as an association: to bring us together and to help build up our members wherever we are in our professional journey.

had real meaning to me. Oh my, has my perspective and understanding changed. I developed a deep appreciation for those who understand and work hard to make a difference every day. One day at a time. One design draft. One clogged pump, one broken pipe, and one quality test at a time. I could go on and on and on. As a youth, I took the beautiful bodies of water I enjoyed playing and recreating in for granted, not knowing what it takes to keep those bodies of water in a condition where we can enjoy them. I chose to give it a shot – to see if I could be part of this movement, along with its mission, in the preservation and enhancement of the water environment.

So, what is your story? Mine just grew from there. I worked as a utility worker, then as an operator, learning quickly that there was a lot more going on than I realized, including all kinds of people doing a wide variety of jobs, including design, construction, installation, regulation, collection, operations, and maintenance (to name a few). It takes all kinds of disciplines working together with different knowledge and experience to make this really happen. I became a belt filter presses operator, working everyday with biosolids. If there was a time to jump ship, I kept telling myself it was then, but because of great

people, the spark of change ignited a flame within me. I learned that what we were doing made a difference in the community, as well as in the world that I share with the people I love. I grew more and began working on the equipment that is used to help make the thoughts of designers, engineers, and scientists become reality. My role was to maintain the equipment that allows the water to go through the treatment process until its restored to its place in the environment.

I am not old or wise, though I am not a young buck anymore. I have learned many things on my journey so far. I have learned them from all of you as you have shared your experiences, your ups and downs, your triumphs and successes. Overall, I have learned that we will continue to rise to the challenge of change, no matter what.

So here we are. Our annual conference was cancelled. We missed the opportunity to be together and share our experiences and the things we have learned over the last year. We have had to self-quarantine and practice social distancing. But with this change, we can grow. We're finding new ways to connect, help and serve each other. We are adapting to our new circumstances. This is one of our many purposes as an association: to bring us together and to

help build up our members wherever we are in our professional journey.

Please look on the WEAU website as virtual trainings become available to help with earning CEU's and learning opportunities. As soon as we can, we will hold them in locations that will help our members. We want to thank our past Board Members that have served our association and welcome our new Board Members. We also want to congratulate all those who received Individual Awards, Facility Awards, Program Awards, and WEF Awards. These will be posted on the website. We will hand them out either at their facilities or at the Midyear Conference. We are sad that we didn't get to see and participate this year in our annual Operations Challenge. It is always a great competition that brings us together for some fun and excitement as we cheer each other on in a great spirit of camaraderie and appreciation. We are preparing for and planning a special two-day Midyear Conference, where we hope to be able to reunite as members. So, watch for an announcement as events continue to unfold.

We invite you all to stay connected with your loved ones, your friends, and with each other as we move forward with whatever change lies ahead.

Once again – thanks for all you do. **DN**



We Didn't Start the Fire 🎵

Bryan Mansell

Welcome to wildfire season. Fires have already started out here in the west and will likely increase throughout the summer. We hear about them so often each year but not much is said about their effects on water quality. As I am in business of protecting the water environment, I've been thinking about these impacts. I also wonder whether the effects will be worse this year due to the current trend of everyone and their dog (literally) enjoying the outdoors, likely leading to more accidental wildfires. Well, thanks to our mutual acquaintance, COVID-19, I had a few minutes to research the topic.

The USGS tracks this issue carefully. The overall impact of wildfires on water is far-reaching and long-lasting. Wildfires affect water supply, drinking water treatment, treated water quality, and of course, downstream receiving waters. An article prepared by the USGS California Water Science Center entitled *Water Quality after a Wildfire* (see USGS website) includes the following list of impacts:

- Changes in the magnitude and timing of snowmelt runoff, which influence filling of water-supply reservoirs.
- Increased sediment loading of water-supply reservoirs, shortened reservoir lifetime, and increased maintenance costs.
- Increased loading of streams with nutrients, dissolved organic carbon, major ions, and metals.
- Post-fire erosion and transport of sediment and debris to downstream water-treatment plants, water-supply reservoirs, and aquatic ecosystems.
- Increased turbidity (cloudiness caused by suspended material), or heightened iron and manganese concentrations, which may increase chemical treatment requirements and produce larger volumes of sludge, both of which would raise operating costs.



Photo borrowed from: www.cbs3duluth.com/2020/05/12/international-falls-smokey-the-bear-dons-face-mask-during-covid-19-pandemic/#.XsglMS6_eE.email

“ Be watchful and willing to speak up when others act recklessly. Our water environment depends on it.

- Changes in source-water chemistry that can alter drinking-water treatment. So, the effect on downstream ecology can be dire as their ecosystem is invaded by suspended solids, dissolved organics, metals, and other chemicals; or as their home is eroded by rapid runoff. USGS reports that urban fires can have an even more pronounced effect on downstream water quality due to the abundance of harmful chemicals in developed areas.

With these thoughts in mind, I encourage you to do a little research of your own to learn more. More importantly, let's all pretend this summer that Smokey Bear is standing six feet away from us wearing his N95 mask as we thoughtfully and responsibly practice fire safety in our recreational activities. Likewise, be watchful and willing to speak up when others act recklessly. Our water environment depends on it. [DM](#)

When **THEY** break your heart...

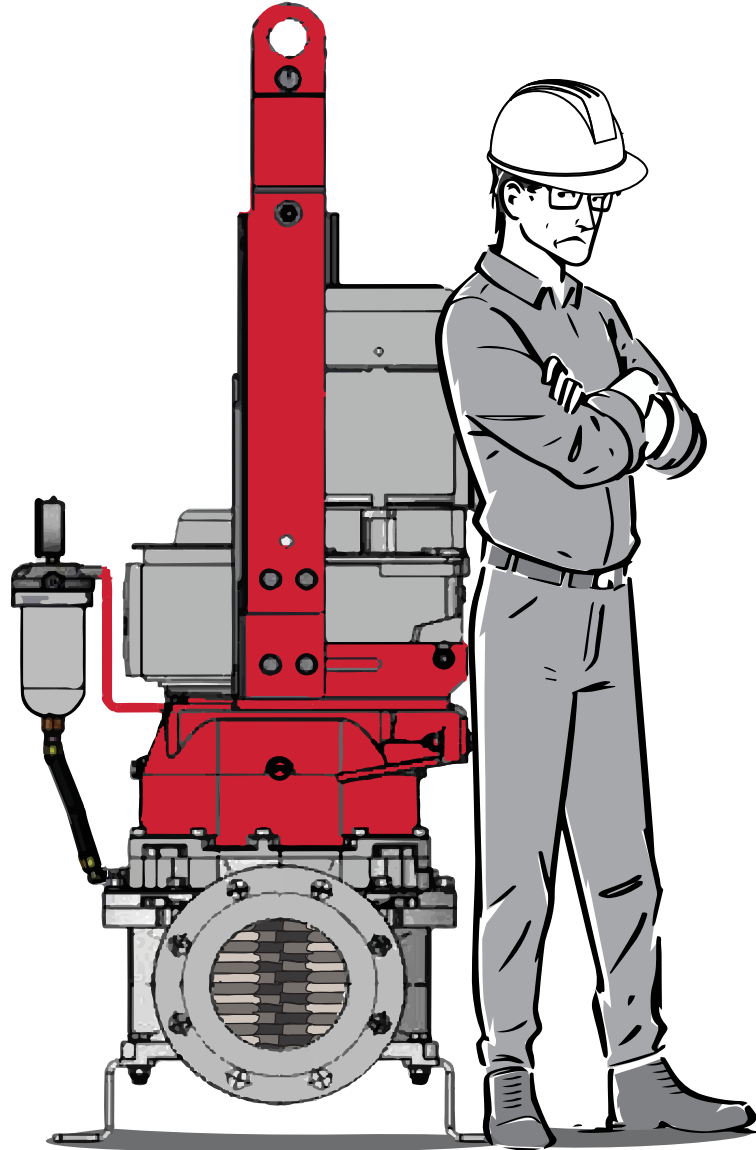

We're ready to grind!

Contact us today to see how our grinders drive
Precision, Performance & Protection.

- ✔ Protect your pumps
- ✔ Avoid costly repairs

- ✔ Prevent dirty clean ups
- ✔ Proven reliability



Authorized Distributor

Waterford Systems

Salt Lake City, UT 84109

(801) 463-9900

jeff.waterford@gmail.com



*Protecting pumps and system components from clogging,
blockages, and damage for over 45 years.*

Operator Spotlight: Tom Anderson

Tom has worked for the North Davis Sewer District for 10 years now. In his career, Tom has acquired a handful of schooling and certifications, including a degree in Construction Management, and Grade 4 certification in Treatment and Collections, Grade 3 certification in Plant Maintenance. He also just became a licensed electrician. Tom started at the District as a plant operator and currently works in the Electrician Department. Tom is currently the Co-Chair for the Operations Challenge in WEAU. He has been involved in the Operations Challenge for many years, competing at the WEAU Annual Conference nine times and representing WEAU at WEFTEC seven times.

Tom is a family man with a wife (Lindsey) and two little girls. He enjoys camping and outdoor activities with them. He is known as being the 'Dance Dad', as he is tasked with getting his girls to and from dance practice and their recitals. Tom and his dad try to attend an NFL game at least once a year at a different stadium. He is also a die-hard New York Yankees fan. He and his wife even spent a couple weeks last year traveling to all the games. [m](#)



You'll Retire Before It Does.



EVERLAST™
Wastewater & Stormwater Pump Stations

Stop Flushables. Simply. Safely.



S&L EVERLAST™ Wet Well Mounted Pump Stations offer you the easiest and safest O&M with no confined space entry, non-clog pumping, long-lasting reliable performance, and when the time comes... simple life-extending retrofits. Backed by the longest warranty protection in the industry, EVERLAST™ pump stations are built to last—so long that you will retire before it does! **But don't wait. Specify EVERLAST™ today.**

Represented in Utah by:

Waterford Systems

Phone: 801-463-9900



Smith & Loveless Inc.

WEAU Collections College Tentative Fall 2020 Class Schedule

Date	Chapter	Tests
August 12		Math Review Packet
August 20 (Thursday)	1 & 2	Ch. 1 & 2 B Math 1, A Math 2
August 26	3 & 11	Ch. 3 & 11 B Math 2, A Math 4
September 2	4	Ch.4 & B Math 4, A Math 5
September 9	5 & 6	Ch. 5 & 6, B Math 5, A Math 6
September 16	8	Ch. 8, B Math 6, A Math 7
September 23	9	Ch. 9, B Math 7, A Math 8 Turn in test application to DEQ
September 30		Fall Break No Class
October 7		WEFTEC Break, No Class
October 14	10	Ch. 10, B Math 8, Mini Review
October 22 (Thursday)	12	Ch. 12, Adv. Practice problems
October 28	13 & 14	Ch.13 & 14, 100 question test
November 4		Last minute review
November 5 (Thursday)		Test, Good Luck

Read the Sacramento, Ken Kerri manuals titled Operation and Maintenance of Wastewater Collection Systems, 7th or 8th Edition, Volume 1 & 7th Edition Volume 2. The manuals can be purchased at www.owp.csus.edu/courses/wastewater.php.

Do the chapter tests as you read. For example, by August 20, you should have read chapters 1 and 2 and have finished the test. Classes start at 12:30 pm and go until 3:30 pm. Along with the chapter test you will get two sets of math sheets each week, the B (beginning) math series is for people just starting out. The A (advanced) math is for people who have taken and passed a test before and need training for a higher test. There is **no cost** for the class, but a contribution of a ream of paper per student is appreciated, it will be given it back as handouts.

Taking this class does not guarantee you will pass. The more you study outside of class the better the chances are of passing. Please call Lon Rasmussen at 801-943-7671 with questions and to sign up. 

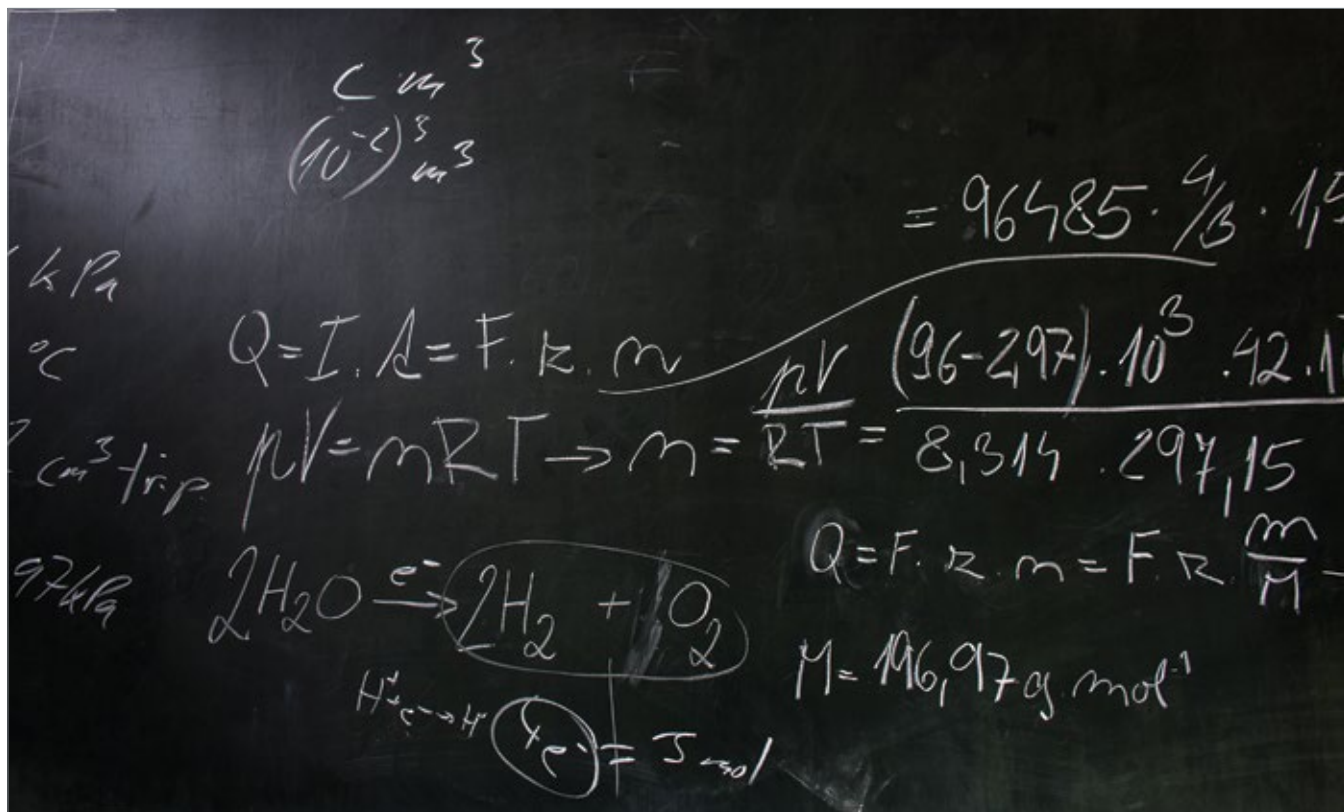

Let's Talk Confinement

- 1. **A confined space by definition is large enough that an employee can enter and perform assigned work, has limited or restricted means for entry or exit and _____.**
 - A. Have a dangerous atmosphere
 - B. Converging or sloping floor that can entrap
 - C. Is not designed for continuous employee occupancy
 - D. Engulfment

- 2. **A permit-required confined space is one which could contain a hazardous atmosphere, have the potential to engulf the entrant (yuck, death by drowning in sewage), have converging floors and _____.**
 - A. Contain any other recognized hazard
 - B. Not have a ladder
 - C. Be difficult to rescue from
 - D. Have multiple entrants

- 3. **In wastewater collections, what four gasses should your air detector monitor? Oxygen, Hydrogen Sulfide, Methane and _____?**
 - A. Nitrogen
 - B. Carbon Dioxide
 - C. Carbon Monoxide
 - D. Dihydrogen Monoxide

- 4. **What makes a manhole a permit-required confined space?**

- 5. **Is your employer required to train you prior to entering a confined space?**

- 6. **Would the wet well of a lift station be considered a permit confined space?**

- 7. **Which of the following are required on a confined space permit?**
 - A. Permit space, purpose, date, and authorized entrants
 - B. Hazards of space, control methods, acceptable entry conditions, and results of entry
 - C. Rescue and emergency services, communication procedures, and equipment
 - D. All of the above

- 8. **Air detectors are set to alarm at what % of oxygen?**
 - A. 20.9%
 - B. 16.5%
 - C. 19.5%
 - D. 22.9%

- 9. **In confined space accidents sometimes more rescuers die than entrants, why?**
 - A. They get caught up in the moment
 - B. They just want to help
 - C. They don't understand the dangers
 - D. All of the above

- 10. **Your family is dealing being confined with each other by?**
 - A. Plotting to overthrow the authority figure
 - B. Coming up with novel ways to torture each other
 - C. Excitedly dreaming of the day when escape is possible
 - D. Learning to become a caring, loving family

ANSWERS:
1-C, 2-A, 3-C, 4-Tapered bottom, Engulfment, Hazardous Environment, 5-Yes, OSHA requires this training for everyone who may work in a confined space, 6-Yes, limited entry and exit, engulfment, sloping floors and hazardous atmosphere, 7-D, 8-C, 9-D, 10-A, B or C, not D, I'm not buying it.

Brought to you by the
WEAU Collection Committee



Times of Challenge

By Christi Priest, Pretreatment Coordinator, Central Valley Water Reclamation Facility

What can be said in a world of isolation and social distancing? Trying to stay connected by staying apart – it is confusing. Things are on hold and people are scared. Going to the grocery store is like going to a third world country. All the shelves are empty, and you lock eyes with someone and do a little dance trying to get six feet away from them. We must do like Tyra Banks says and learn to “smile with our eyes” because the rest of our faces are covered with masks.

In our work life, we have had all our networking opportunities shut down – Local training, the WEAU Conference, and Region 8 pretreatment events. We all look forward to these conferences and opportunities every year. These have always been the times in pretreatment that we would get together and discuss our industries, talking openly about our thoughts and concerns. We learn about EPA and State updates and find out what to look for in the future. Most importantly, we get to make connections in

person and see friends and colleagues that we may only see once a year.

Pretreatment had a virtual training on April 28. Jennifer Robinson did a two-hour presentation on Submittals to the State and what is considered a substantial or minor submittal. We also discussed some questions that people have with their programs, including Dental Amalgam, pharmaceuticals, and permitting the CBD producers. I think it went better than anyone imagined it would, and that we are all doing a great job at getting things in place to work from home and communicate by internet.

As I write this, I am working two days a week from home, helping my 15-year-old son stay on track with his school. We as humans are being pressed to our limits. We have become full time essential workers, schoolteachers, entertainment directors, and psychiatrists. Our children have no one to interact with but us. I know for my teenager this is driving him insane. Oh, and

on top of everything let’s add a 5.7 earthquake, just to make things interesting. I have heard the best way to get through this is to stay busy. I signed up for a free Harvard class – yes, I am now a Harvard student. It is called the “Science of Being Happy.” I thought this was fitting. I try to take a walk every night. My son tries to get me to do the Jedi workout with him for his P.E. class. I must take a pass, as that would kill me. If you have not seen what you do for the Jedi work out, I encourage you to Google it. I will stick with the walking.

What I have learned from quarantine is we are all stronger than we think we are and no matter what, we all come together and help in a crisis.

I will leave you with this:
“The ultimate measure of a man is not where he stands in moments of comfort and convenience but where he stands in times of challenge and controversy.”

– Martin Luther King Jr. 

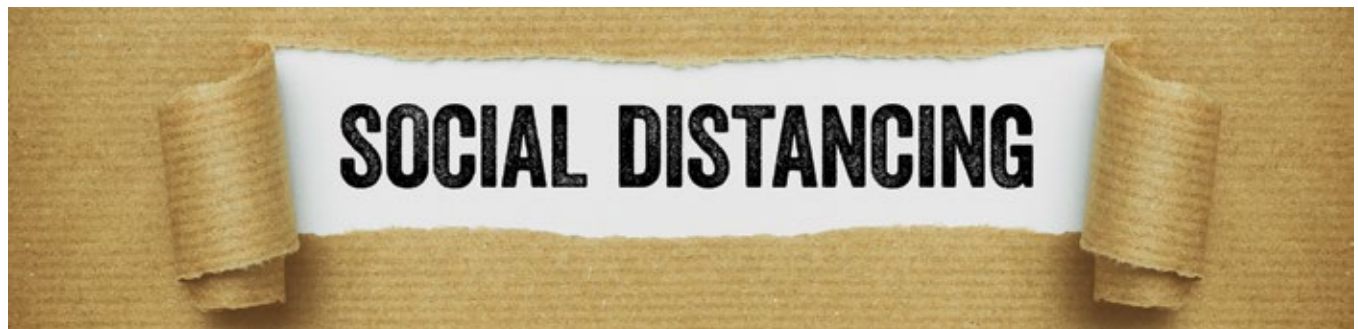

Retirement Announcement: Fernando Alanis

By Christi Priest



Fernando, Fernando, Fernando oh how you will be missed!

We would like to congratulate Fernando Alanis on his retirement May 14, 2020. He began his career in wastewater in 1995 and has worked for Central Valley Water Reclamation Facility, South Valley Water Reclamation facility and is retiring from South Valley Sewer District in the pretreatment department.

Steve Claybrook says of Fernando “He is very proud of his knowledge and work he has done in the field of pretreatment, and proudly boasts that he leaves the business having never broken a single sample bottle. I can attest as his supervisor that his work has always thorough and accurate, and he has been, to the end, a loyal and reliable member of the pretreatment dept at SVSD. SVSD will certainly miss his historical knowledge of the south Salt Lake County area, and of course his easy smile, friendly demeanor, and positive attitude.”

Fernando has made a lasting impression on everyone in the pretreatment community and although we are happy for his retirement, we are sad to see him go. Fernando your smile will forever be in our hearts. 

Mona Wastewater Treatment Plant
Mona, UT



Top-Ranked
WATER/WASTEWATER BUILDER

Archer Western is proud to be listed as the industry's top builder of facilities that gather, treat and distribute our most vital resource.



ARCHER WESTERN

WWW.WALSHGROUP.COM

299 S. MAIN STREET, SUITE 1300 | SALT LAKE CITY, UT 84111 | (801) 534-4440

* As ranked by Engineering News-Record (2019)

IT'S HAPPENING.

The First U.S. AquaNereda® Installation | Riviera Utilities, Wolf Creek WWTP, Foley, AL



AEROBIC GRANULAR SLUDGE TECHNOLOGY

Following its recent introduction to North America, AquaNereda® Aerobic Granular Sludge Technology is quickly becoming the most sought-after wastewater treatment system in the U.S. and Canada with many plants in design and several plants currently under construction.

Consultants and end-users have realized the process and cost saving benefits associated with AquaNereda technology through on-site pilot testing, installation visits and technical seminars. The result is complete confidence in a progressive technology that ensures full plant compliance and peace of mind.

- Exceptional effluent without chemical addition
- Designed to meet or exceed nutrient removal demands
- Small footprint that easily retrofits into existing basins
- Reduced cost due to minimal civil site construction
- Low total cost of ownership



SVI₅ comparison of aerobic granular sludge (left) and conventional activated sludge (right)

Proudly Represented By:



Davidson Sales & Engineering
West Valley City, Utah
p. 801-823-6006 e. info@dseslc.com
www.dseslc.com



AQUA-AEROBIC SYSTEMS, INC.
A Metawater Company

www.AquaNereda.com | 815-654-2501

Aqua-Aerobic Systems, Inc. is the exclusive U.S. and Canada provider of Nereda® technology developed by Royal HaskoningDHV.

A Bear of a Quiz

Test Your Knowledge on: Laboratory Quality Control



1. A group of data from the same sample, are all close in values to each other the data is said to be:
 - A. Accurate
 - B. Certain
 - C. Precise
 - D. Reproducible
2. Stock standards are used to develop:
 - A. Accuracy charts
 - B. Control charts
 - C. Equipment charts
 - D. Precision charts
3. What is used to account for container contamination?
 - A. Equipment blank
 - B. Field blank
 - C. Method blank
 - D. Sample blank
4. One of the simplest methods to check quality control is:
 - A. Blanks
 - B. Dilutions
 - C. Duplicates
 - D. Recovery
5. What is the maximum holding time for an *Echerichia coli* sample?
 - A. 1 hour
 - B. 6 hours
 - C. 12 hours
 - D. 24 hours
6. The higher the percent recovery is, the more _____ the test is.
 - A. Accurate
 - B. Certain
 - C. Precise
 - D. Reproducible
7. The concentration which has a 99% probability that the value is greater than the blank is known as the:
 - A. Instrument detection limit
 - B. Method detection limit
 - C. Quantitative detection limit
 - D. Reporting detection limit
8. What blank can be subtracted from results data for reporting?
 - A. Equipment blank
 - B. Field blank
 - C. Method blank
 - D. Sample blank
9. What is the maximum acceptable level of a field blank for low level mercury sample?
 - A. 0.2 ng/L
 - B. 0.5 ng/L
 - C. 1/5 sample
 - D. 1/3 sample
10. What are the typical boundaries on a control chart?
 - A. The variance
 - B. Twice the variance
 - C. Standard deviation
 - D. Twice standard deviation

ANSWERS:

1-C, 2-B, 3-B, 4-C, 5-B, 6-A, 7-B, 8-B, 9-C, 10-D



Representing the Wastewater Industry in Utah, Idaho, Nevada, Wyoming, California
www.goblesampson.com 801-268-8790



NICO
NICKERSON COMPANY, INC.

Leading Pump Sales & Service Since 1924



PENTAIR HYDROMATIC®

NICOPUMPS.COM • 800-584-6973

OUR TECHNOLOGY IS BASED ON SOUND SCIENCE

Inspect More, Clean Better

Active Acoustics screen for blockage with no flow contact

MILLIONS OF FEET INSPECTED

- Save time, water, AND money
- Screen 2+ miles per day
- EPA validated
- Highly portable and easy to operate



SL-RAT

InfoSense, Inc
Innovating Acoustic Inspection Technology
877-747-3245
sales@infosense.com • www.infosense.com

PIPELINE

Pipeline Inspection Services
www.pipelineinc.us

SPRAYROD
the gold standard
Protective Lining Systems

Specializing in the Trenchless Rehabilitation and Repair of Manholes, Sewer Lines and Storm Drain Pipes & Structures in Idaho & Utah Since 2003!

Contact us today to learn more about our trenchless pipe & manhole rehabilitation, linings & structural coatings, or to request an evaluation or proposal for services!

<p>Manhole Rehabilitation Structural Coatings</p> 	<p>Infiltration Repairs</p> 	<p>CIPP Lining & Point Repairs</p>  <p>Locations West Jordan UT (801) 719-9429 Nampa ID (208) 465-3444</p>
--	--	---

EMAIL: pipeline@pipelineinc.us

COVID-19 Life for Operators

By Tyler Barfuss

Driving into work with staggered start times. Upon arrival, getting your temperature taken and recorded. Then, proceeding to get changed into a work uniform in what was once was a packed locker room full of casual conversation about the weekend activities but is now a quiet deserted area with two people getting ready at each end of the locker room. Heading to work areas with only one person in each vehicle or golf cart trying to complete the daily work while practicing social distancing. Staggering breaks and lunches to avoid being in contact with another person in multiple break rooms. Having bleach solutions to wipe down door handles and counter tops. This is how the North Davis Sewer District has been running since the COVID-19 outbreak. It has made things kind of depressing, which I am sure all of you are also experiencing in some fashion. Cross your fingers that we can get back to normal life soon.

However, we all need to see the light at the end of the tunnel. These things are in place for our safety and wellbeing. In this crazy time, not everything we have implemented has been for the worse. One change that is being looked at here at North Davis is keeping our new shift schedule. This is something a lot of employees have been advocating for. We have changed start times and work hours and have shown we are getting more accomplished. With all the safety requirements that need to take place now days we can work for longer on a project before it is time to break everything down

for the day. This is extra helpful in our collections department with setting up traffic control, which normally uses up available time on U-Dot roadways. The use of online meetings has also been a new thing implemented, enabling us to have meetings with contractors and staff without having to travel to different locations. We have also been attending online webinars to get CEU's. It has been nice to attend a class without having to use a whole day to drive to and from a location.

The new shift schedule and online meetings may be how we conduct business in the future. So, despite the challenges of COVID-19, we have used the experience to improve ourselves and try new things that have proven to be productive in our company. Sometimes change is a hard thing; but it can be a blessing in disguise with new opportunities. I speak for everyone when I say, "I hope we can get back to a more normal life" in the foreseeable future. But until then, stay safe out there! 



“ Sometimes change is a hard thing; but it can be a blessing in disguise with new opportunities. I speak for everyone when I say, “I hope we can get back to a more normal life” in the foreseeable future.

TWIN "D" Inc.



- Pipe Cleaning / Vacuuming
- Video Inspection / Locating
- Tap Cutting / Root Removal
- Lateral Launch Camera
- Hydro Excavation / Potholing
- Rotational Maintenance Plans

NASSCO PACP Certified Operators

3120 N. 675 E. • Layton, UT 84041
www.twind.net • Phone: (801) 771-3038

Can Wastewater Influent Be Used to Track the Spread of COVID-19?

By Jeff Ostermiller, Ken Hoffman, and Erica Gaddis, Utah Division of Water Quality

The COVID-19 pandemic has affected all of our lives. It is a safe bet that the protection of human health has never been more present in our homes and the media. Our lives have been disrupted in ways unthinkable a couple of months ago. Yet, throughout this crisis, our wastewater plant operators have continued working to ensure that this critical infrastructure remains operational and we are grateful for their sacrifice and commitment. Wastewater facilities now may have yet another opportunity to help and serve their communities through the COVID-19 pandemic through wastewater epidemiology.

Wastewater epidemiology refers to the analysis of human waste to better understand community level patterns in the spread of disease. People shed viruses and other disease indicators in their waste, which can then be detected in wastewater influent. This field is not new. For example, the analysis of wastewater was widely used in polio eradication programs around the world by identifying areas where vaccinations were most needed or areas where outbreaks were most likely to occur. More recently, the process has been used in some parts of the country to better understand patterns of the opioid epidemic.

“People shed viruses and other disease indicators in their waste, which can then be detected in wastewater influent.”

The latest application of these ideas and methods is for the COVID-19 pandemic. Researchers around the world have begun quantifying the concentration of viral gene (RNA) copies in wastewater. COVID-19 has a single strand of RNA and, like all viruses, cannot replicate outside of a host cell, so each copy found in wastewater is assumed to reflect an individual virus that has been shed by someone with the illness.

According to Dr. Jennifer Weidhaas [University of Utah (UU)] the process of testing wastewater is similar to the process used to test people, “The qPCR process uses a chemical reaction to make many, many copies of the virus genomic material. It is a very sensitive process and allows us to quantify the number of viruses per liter of wastewater influent. The test is actually the same as that recommended by the CDC to detect COVID-19 in hospital patients.”

Importantly, the presence of COVID-19 RNA in wastewater does not necessarily mean that viruses entering our wastewater treatment plants are infectious. There remains very little evidence to evaluate this question with certainty, but the evidence that does exist suggests that most viral particles are no longer viable by the time they reach our treatment plants. However, until more definitive evidence is available an abundance of caution is warranted. Plant operators should remain vigilant and follow their protocols for PPE while operating wastewater treatment systems.

According to Dr. Nathan LaCross of Utah’s Department of Health (DOH) ongoing testing may play a key role in Utah’s

ongoing pandemic response, “It is critically important to continue COVID-19 testing and surveillance efforts, even as we begin to move to lower risk levels. Testing allows public health professionals to identify and track hotspots, identify any resurgence in infection rate, and determine when it may be safe to begin relaxing restrictions on contact and movement.”

In addition to tests of individual patients, it is possible that the presence of COVID-19 genes in wastewater will help reflect the overall rate of infections in or our communities, especially considering that many people who contract COVID-19 are asymptomatic, particularly immediately after becoming infected. This means that widespread wastewater testing has the potential to improve Utah’s ability to identify “hotspots” of infection early or confirm low levels of infection in areas less impacted across the state.

Another potential advantage of COVID-19 wastewater tests is that they may be a leading indicator in any future resurgence of the disease. In a recent Water Research Foundation Symposium on COVID-19 Dr. Gertan Medema, a Wastewater Epidemiologist, noted that on an island in the Netherlands, COVID-19 genes were found in wastewater six days before the first patient tested positive for the disease. If advanced warnings like this can be detected reliably, it may help public health officials to act more quickly in specifically affected communities to minimize spread of the disease.

There is now worldwide interest in COVID-19 wastewater testing among scientists and public health officials. The rapid expansion of these programs mean that scientists learn more every day about the most effective analytical approaches for conducting these tests, but considerable scientific uncertainty remains. For instance, little is known about fecal shedding rates among infected people. There is also a lot of uncertainty about how to minimize sampling and testing errors and variability. Little is presently known about sample variation and this is critically important to predicting whether the concentrations of COVID-19 in wastewater are well correlated with trends in infection rates in communities throughout the state.

A pilot study is currently underway in Utah to fill some of these data gaps and to evaluate whether COVID-19 wastewater test results are sufficiently robust to be used by public health officials as an additional tool for continuing to make evidence-based public policy recommendations.

This investigation grew from efforts of Dr. Weidhaas (UU) in the early stages of the pandemic. To test CDC recommended analytical methods she partnered with Tiffini Adams (Snyderville Basin Water Reclamation District) and Dr. Phil Heck (Central Valley Water Reclamation Facility) to collect and analyze wastewater influent samples. Within a week, they demonstrated that COVID-19 genes could be detected and quantified from these samples.

Based on these early successes, the Division of Water Quality (DWQ) expressed interest in a more thorough evaluation of wastewater influent testing. A partnership was established with Utah’s DOH to better relate the concentration of COVID-19 gene copies to known infections in the service areas of participating facilities. To expand laboratory processing capacity, additional partnerships were also established with Brigham Young University

(Dr. Zach Aanderud) and Utah State University (Dr. Keith Roper).

To better assess the sensitivity of COVID-19 wastewater testing, monitoring efforts were expanded to include communities that encompass the range of known infection rates throughout Utah. Numerous plants from throughout the state volunteered to assist and the research team ultimately selected a total of 10 facilities to participate in the pilot investigation. This includes several facilities in the Bear River Health Department (Logan WWTP, Hyrum WWTP, and Tremonton WWTP), Summit County (Snyderville Basin WRD - East Canyon), Salt Lake County (Central Valley WRF and Salt Lake City WRF), Utah County (Orem City and Timpanogos SSD), and Southeast Health Department (Price WID and Moab WRF).

The pilot investigation was initially planned to take place over three weeks, but was extended for an additional two weeks to capture Utah's transition from high to moderate risk. Twice per week, each facility collects a subsample from the time integrated influent samples that they were already collecting for plant operation and regulatory purposes. To determine if these methods could potentially be used to evaluate smaller spatial scales, Timpanogos SSD and Central Valley WRF have also been providing interceptor samples reflective of smaller communities within their service area. DWQ then transports these samples to the laboratories at each university for sample processing. Laboratory results have generally been available within two to three days.

DWQ has also been working with the facilities, the Department of Health, and the UU School of Public Health to overlay spatial coverage of the treatment plant service areas with population estimates and infection rate data. This will facilitate a direct comparison of COVID-19 gene copies with known infections on the day of sample collection. This exercise is also helping to develop tools to facilitate rapid communication of test results should the pilot project be expanded into a statewide effort.

It is currently too soon to draw conclusions about whether wastewater influent sampling can provide public health officials with actionable information, but preliminary results are encouraging. We have learned much about how to best collect, transport, and process samples.

One thing that is abundantly clear is the dedication of wastewater treatment operators to the protection of public health. These are challenging times, yet every facility that we contacted was willing to add more to their already full plates to help the citizens that they serve. The researchers ultimately selected a smaller subset of these volunteers for this pilot investigation, but others may be involved in the future if health officials determine that the results of this testing will help inform public health decisions.

If you have additional questions about this project, either present or future, please contact Jeff Ostermiller (801-536-4370) or Ken Hoffman (801-536-4313). [DW](#)

skm

save **time**
save **energy**
save **money**

Providing solutions for all electrical, instrumentation and control needs

Call Now **(801) 677-0011**

skmeng.com

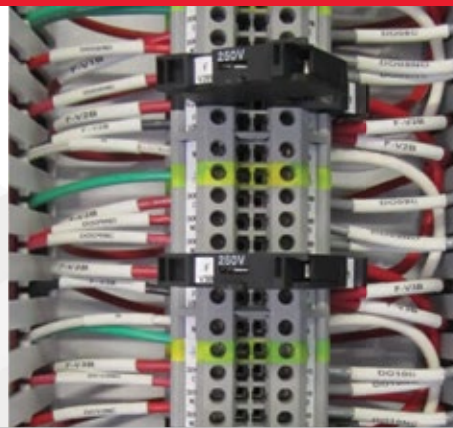

Wastewater / Reuse ♦ Drinking Water ♦ Water Resources

We're engineering stronger communities.

FORSGREN
Associates Inc.

801.364.4785 ♦ Forsgren.com

What Could Municipal Wastewater Sampling Tell About the Coronavirus Epidemic?

By Dr. Ramesh Goel, Professor, Civil & Environmental Engineering, U of Utah

The emergence of a strain of Coronavirus called SARS-CoV-2 has impacted the whole globe with adverse effects on public health, the world economy and people's free will. Towards the end of 2019, a novel human virus in the subgenus group of severe acute respiratory syndrome (SARS) virus, caused a cluster of pneumonia cases in Wuhan, a city in the Hubei Province of China. In no time, this virus became a global pandemic resulting in several mortalities in China, Italy, the US and many other countries. SARS-CoV-2 is a virus of the family *Coronaviridae*, which consists of a group of enveloped viruses, or infectious microorganisms with an outer covering developed through a process called "budding off" from the host infected cell, with a single-stranded RNA genome; many of these coronaviruses, named such due to the crown like appearance of the envelope, have been known to cause common colds. The illness caused by this specific strain of coronavirus is called COVID-19. The disease is widely recognized as a respiratory illness, but a subset of individuals with COVID-19 develop diarrhea, and the virus is found in fecal material.

Sustainable urban water systems are vital to provide the public with drinking water and sanitation services, and to promote the balanced environmental, economic, and social health of communities now and in the future. Municipal wastewater is generated in kitchens and restrooms and is proven to carry human pathogens from human feces, skin, and contaminated food. Recent evidence suggests the presence of SARS-CoV-2 genetic material in municipal wastewater. Hence, municipal wastewater provides an important pathway for COVID-19 to enter the urban water cycle and threaten human health. This finding prompts the need to better understand treated municipal wastewater as potential source for epidemiological data. A first report of the presence of SARS-CoV-2 in human feces emerged from research in China (Zhou et al., 2020). Likewise, another investigation by Holshue et al., (2020) found SARS-CoV-2 RNA in human feces. Yet, another publication from Australia related to surveillance of wastewater treatment plants confirmed the presence of SARS-CoV-2 in wastewater influents.



Travis Potter and Chad Burrell from the Snyderville Basin Water Reclamation District install a composite sampler inside one of the interceptors.

These findings are pivotal and suggest wastewater treatment plants could potentially serve as tracking tools to determine community outbreak of SARS-CoV-2.

Research in Dr. Goel's Lab

Dr. Ramesh Goel's lab at the University of Utah has been sampling several wastewater treatment plants in Utah for influent, effluent, and interceptor samples. The objective is to look at increasing or decreasing trends of SARS-CoV-2 infections in a community associated with each wastewater treatment plant.

Pictures show Mr. Travis Potter and Mr. Chad Burrell from the Snyderville Basin Water Reclamation District installing a composite sampler inside one of the interceptors. The second picture shows one of Dr. Goel's lab associates collecting wastewater samples.

In addition to Snyderville Basin Water Reclamation District, shown in picture A, other utilities participating include the Central Valley Water Reclamation Facility (CVWRF), Central Davis Sewer District, Provo City, South Valley and North Davis Sewer District.

The collected samples have been analyzed using a genomic technique known as reverse transcription-quantitative polymerase chain reaction (RT-qPCR). The two most common genomic materials included are ribonucleic acid (RNA) and deoxyribonucleic acid (DNA). SARS-CoV-2 contains RNA as its genetic material, much like most human viruses. In the quantification methodology a known volume of the wastewater is filtered through a membrane filter after acidifying the sample to a pH of nearly 3.6. The viruses are recovered on the filter paper and the genomic content (e.g. RNA) is extracted directly from the filter paper containing biomass using biochemical procedures. The quantity and quality of extracted total RNA is checked on a special instrument and the sample RNA is stored at -80°C for further processing. Since the extracted RNA comes from a variety of sources including bacteria and other viruses, biomarkers very specific to SARS-CoV-2 are used in the process called RT-qPCR to quantify RNA gene copy number present in the extracted RNA. The gene copy numbers are correlated back to the total filtered volume using a simple calculation accounting



One of Dr. Goel's lab associates collects wastewater samples.

for total volume filtered and total volume of buffer used to suspend the RNA in solution. Based on the analyses so far, some plant influents have shown positive responses and some have shown negative. The good news is that this analysis so far has not found any SARS-CoV-2 in treated effluents. This leads us to believe that the disinfection practices in place at various wastewater treatment facilities are very efficient in ensuring the disinfection of final effluent and integrity of receiving waters.

Extensive quality controls and other calculations are ongoing to confirm results and make sure that the analytical methods used are robust enough to enable convincing results. Dr. Goel's lab, in collaboration with other researchers from the University of Utah's departments of physics and genetics are studying many other aspects of SARS-CoV-2 related to its survivability, persistence and genomic structure.

Implications to Wastewater Operators

Much like in the rest of nation, Utah wastewater treatment plant operators follow comprehensive and intensive plant operation and sampling procedures. Since, wastewater treatment plants are regulated under national and/or Utah State Pollution Discharge elimination programs, nearly all WWTPs are required to conduct routine monitoring for various contaminants including nitrogen, organic carbon, dissolved oxygen, and pH. The presence of other human viruses such as adenoviruses and norovirus has been a proven contaminant for WWTP influents. However, it is further advised that personnel sampling and testing raw influent wear

proper PPE during sample collection and processing for routine monitoring. Safe workplace hygiene practices and standard operating procedures will further ensure health and safety of WWTP personnel. WWTP plant managers are requested to further visit the OSHA website for more directions. The US Center for Disease Control (CDC) and World Health Organization have been very active in publishing suitable information related to the occurrence and spread of COVID-19 disease. COVID-19 disease is believed to spread from person-to-person during close contact, mainly via respiratory droplets produced when an infected person coughs or sneezes, similar to how other influenza pathogens are spread.

Acknowledgements

Dr. Goel's lab dedicates this short informative essay to all participating utilities in Utah without the help of which it would not have been possible to collect some critical data for the presence of SARS-CoV-2 in Utah waters. We also appreciate the US National Science Foundation for funding this research. However, the views expressed in this short manuscript are those of author and have nothing to do with the funding agency. Special thanks to all graduate students, primarily Quinn, Aditi, Eddie, Bishav, Hong, and Nathan for helping with sampling, driving nearly 250 to 300 miles per week to collect samples and process them.

Bibliography: (1) Holshue et al., (2020); New England Journal of Medicine, (2) Water Environment and Technology: Operations and Engineering Magazine; April 2020, (3) Zhou et al., 2020; Nature. [DN](#)



INNOVATIVE ENGINEERING SOLUTIONS



aquaeng.com | 801.299.1327



Bowen Collins & Associates, Inc.
CONSULTING ENGINEERS

- Water
- Wastewater
- Water Resources
- Natural Resources
- Civil Engineering
- Electrical Engineering
- Structural Engineering
- SCADA
- Studies/Master Planning
- GIS Mapping
- Construction Management
- Environmental



SALT LAKE CITY
(801) 495-2224

ST. GEORGE
(435) 656-3299

BOISE
(208) 939-9561

WWW.BOWENCOLLINS.COM

Flexible Operator Certification/ Credentialing Requirements During COVID-19 Response

On behalf of our combined nationwide memberships, the Water Environment Federation (WEF) and the American Water Works Association (AWWA) want to thank you, your staff, and your peers in other state certification/credentialing programs for your work responding to the COVID-19 crisis. Working together, the water sector is proving that we can continue to provide the vital services of water distribution, wastewater collection, water and wastewater treatment so necessary to ensuring public health and protecting the environment under very challenging conditions. Thank you!

As the response to the COVID-19 pandemic continues, the need for social distancing and other factors are limiting drinking water operators' and wastewater operators' ability to meet operator certification/credentialing requirements. Current operator certification/credentialing requirements do not consider the challenges posed by the pandemic as operators attempt to obtain necessary course work and continuing education credits. Drinking water and wastewater systems must have appropriately certified/credentialed employees to operate. WEF and AWWA members in some states continue to encounter difficulties accessing training to renew or upgrade operator certifications/credentials.

Specific challenges include:

1. State deadlines for the renewal of operator licenses that cannot be met using available educational opportunities.
2. Lack of state approval to utilize online courses to meet operator certification requirements.

We appreciate the steps that state programs, including your own, have taken to facilitate operator certification/credentialing during the current pandemic.

We strongly encourage agencies that have not yet done so to consider, where statutes permit, instituting flexibility or grace periods regarding renewal dates and expediting approval of online courses and training.

Even as some states reduce social distancing requirements, large group events may continue to be prohibited, and measures remain in place to protect essential workers, including travel restrictions. Consequently, many operators are unable to attend in-person training sessions necessary to obtain required continuing education credits. To improve the availability of classes, WEF and AWWA, in concert with our state affiliates, are enhancing our delivery of online training and education opportunities. If you have any thoughts on what type of content would best serve your constituents, we would like to hear from you. We encourage you to reach out and let us know what actions you may have already taken.

Increased interstate cooperation could potentially contribute to greater resilience by expediting the restoration of essential services to your communities. We urge you to explore the creation of reciprocity policies with contiguous states during emergencies and extreme weather events.

WEF and AWWA are dedicated to the protection of public health and the environment and look forward to continuing to partner with you to help our communities to fight and prevail over COVID-19 and

its impacts. Should you have questions or want to engage further to collaborate in this effort, please contact our local affiliates, Claudio TERNIEDEN, WEF Government Affairs, at cternieden@wef.org or Steve Via, AWWA, Federal Affairs, at svia@awwa.org.

Best regards,



Jacqueline A. Jarrell
President
Water Environment Federation

Walter T. Marlowe
Executive Director
Water Environment Federation

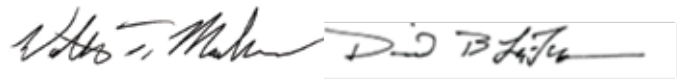

James R. Williams
President
American Water Works Association

David B. LaFrance
Chief Executive Officer
American Water Works Association

WHO WE ARE:

The Water Environment Federation (WEF) is a not-for-profit technical and educational organization of 35,000 individual members and 75 affiliated Member Associations representing water quality professionals around the world. Since 1928, WEF and its members have protected public health and the environment. As a global water sector leader, our mission is to connect water professionals; enrich the expertise of water professionals; increase the awareness of the impact and value of water; and provide a platform for water sector innovation.



The American Water Works Association is an international, nonprofit, scientific and educational society dedicated to providing total water solutions assuring the effective management of water. Founded in 1881, the Association is the largest organization of water supply professionals in the world. Our membership includes more than 4,000 utilities that supply roughly 80 percent of the nation's drinking water and treat almost half of the nation's wastewater. Our 50,000-plus total membership represents the full spectrum of the water community: public water and wastewater systems, environmental advocates, scientists, academicians, and others who hold a genuine interest in water, our most important resource. AWWA unites the diverse water community to advance public health, safety, the economy, and the environment. [DRI](#)

LESS IS MORE



sealless

glandless

oilless

less friction

less stress



Less Wear = Longer Life

Up to 10 times longer run time and up to 70% less maintenance than rotary positive displacement pumps.

Thanks to the "non-captive", free disc design of PVP Double Disc Pumps™, friction is minimized, repairs are reduced and clogs are almost non-existent.

Represented by:



Phone: 801-268-8790
Contact: Dave Ritter
Email: dritter@goblesampson.com

Learn how to get more
from your pump at
PennValleyPump.com
800-311-3311



REVOLUTIONARY TECHNOLOGY Delivers Major Leak Reduction

A study from Utah State University found that 16% of installed water mains in the US and Canada are beyond their useful life, in some cases losing up to 30% of water through leaks. A new acoustic sensor technology is seeing impressive results in the UK and could be a game-changer for global leak detection, says Dale Hartley, consultant at Primayer.

Leaks are a serious concern for water utilities all across the world and locating them in large diameter and plastic pipes can be a particular challenge.

It is not just a case of water not reaching the end user – leaks are expensive. They force utilities to fill the gaps in supply by drawing on freshwater supplies, thereby impacting aquatic habitats, reducing efficiency in water networks, contributing to future water system failures and allowing contaminants to enter the water supply.

According to the American Society of Civil Engineers' 2017 Infrastructure Report Card, which is published every four years, there are about two trillion gallons of treated water lost in the US each year.

A 2018 study into *Water Main Break Rates in the USA and Canada* by Professor Steven Folkman of Utah State University found that 16% of installed water mains are beyond their useful life and utilities do not

have the funds to replace them. Folkman reports that his basic survey gathered data from 201 utilities and that an average of 10% of water put into the system was lost due to leakage. In some cases the scale of water lost through water mains leakage is reaching critical levels of 20% to 30%.

Market intelligence from Northeast Group shows that in non-western countries the problem is even more serious. In the Indian city of Delhi, for example, water loss from leaks has reached 53%. India's official non-revenue water rate is 34% and other emerging nations are seeing losses up to 38%.

Market Forecast

The Northeast Group forecasts a massive increase in deployment of water management technology in order to deal with this problem, to somewhere in the order of US\$46.5 billion of investment by 2023. This includes technology such as smart water meters, precision agriculture and irrigation systems and advanced software analytics solutions.

This technology could in turn generate operational cost reductions of 3%-5% while also increasing the accuracy of billing and enhancing leak detection. Leaks in long-distance and plastic pipelines are a particular problem in terms of detection and

Anglian Water, a utility in eastern England, has responded by deploying Primayer's Enigma3hyQ immersed acoustic sensors.

The Enigma3hyQ was developed in partnership with UK technology company Primayer to address hard-to-find leaks, particularly from large diameter and plastic pipes. In the UK average leakage stands at 20% and water companies in England & Wales are being asked to cut losses by a minimum of 15% in the period 2020-25; halving them by 2050.

Primayer's Enigma3hyQ is a multi-point noise correlation system which has been developed from, and is a variant, of the Enigma3m; both devices use cellular communications.

The hydrophone sensors are placed permanently within a pipe, deployed below-ground. They locate leaks by capturing their acoustic signature, which is particularly groundbreaking for leak detection over longer distances and on large-diameter and plastic pipes.

The Enigma3hyQ delivers a distinct advantage over conventional accelerometer sensors, which have a reduced ability to detect noise from leaks in cases of limited sound propagation. These intelligent sensors transmit daily leak noise data to the Primayer server.



This time synchronisation data is then correlated in order to accurately identify the presence and location of leaks, helping to confirm that the correlation results are accurate and due to leak noise.

Precise Location

The location of each sensor can also be displayed on Google Maps and these locations can be coded to show leak alarms. Historical data is also available and, together with the visualisation of leak locations on Google Maps and Street View, assists leakage teams with management of leaks.

The following day, the sensors transfer the GPS location information and sound files to the PrimeWeb interface where the device operator can create a network diagram. The operator can also change the linear pipeline from a Geographic Information System (GIS) if the distances from the default Google Maps application are incorrect.

Confirmation of the probability that the noise correlation has been successful is provided to the operator in the form of a confidence factor.

Andy Smith, leakage optimisation manager at Anglian Water said, "One of the biggest challenges faced across the water industry is the ability to detect leaks effectively on plastic pipes as they don't transmit noise when they leak. Critically, unlike more widely used methods, this new technology can be used on plastic pipes, which make up 60% of our water mains.

"This is a real game-changer in how we tackle leakage in terms of our teams on the ground and the processes we use. It will revolutionise what we do in terms of leakage.

"We very much created the technology together. We didn't want to just accept what was on offer, we wanted to collaborate to drive for the best solution for the challenge we faced.

"Working with our in-house data team we've also developed a dedicated modelling system which works out the optimum points across the water mains network to place the sensors. This precise deployment means the noise loggers can be installed much more efficiently."

Anglian Roll-out

The project has resulted in a 1.4 million litre per day reduction in the areas where work has completed – a 35% shift in those areas. Initial trials with Anglian, on 40 km of mains in the town of Louth, Lincolnshire, showed the sensors were effective in accurately finding leaks over long distances of up to 4.6 m, and inside pipes made from a large range of materials, including plastic.

So far, 2,023 loggers have been installed and 1,325 leaks found from 1,600 potential leak locations identified. This represents a conversion rate of 83%, which is exceptionally high.

The system is now being rolled-out across Anglian's whole network.



Correlation Analysis

One feature of the Enigma3 technology - Multiday - will aggregate the sound files to form a much longer sound file for correlation analysis. The approximate location of the leak was shown on Google Street View to assist planning for the repair activity.

Primayer, part of Sheffield headquartered Servelec Technologies is based in Hampshire, UK and has been manufacturing intelligent technologies for the global water network monitoring, leakage control and flow measurement market for over 20 years. Its research and development team works closely with utility field teams and their partners to develop best-in-class technologies that directly meet industry requirements.

The company is one of ten jointly awarded the £40 million (US\$53 million) framework agreement with Anglian Water for leak detection products, the aim being to ensure that the utility has as wide as possible a selection of equipment.

Barbara Hathaway, technical services director at Primayer, says, "Results from these trials of the Enigma3hyQ hydrophone sensor for leak detection, with Anglian Water, show fantastic promise. We anticipate a rapid uptake of this revolutionary technology worldwide."

Dale Hartley is a consultant at Primayer and has over 20 years experience with international projects. Areas of specialisation include live pipeline condition assessment, acoustic technology, flow & pressure monitoring, and advanced pressure management. [Dn](#)



VAL KOTTER & SONS, INC.

**VAL KOTTER
OWNER**

**PHONE
(435) 734-9598**

**MOBILE
(435) 720-0237**

**FAX
(435) 734-9870**

Sewer Cleaning (6"-36") - Cleaning (36" & UP) No Bypass Pumping Required
Specialized Equipment • CCTV Inspection • (NASSO-PACP) Certified Technicians
• Leak Sealing Sewer & Storm Drains (8"-36") • Manhole Leak Repairs
• Link Pipe Spot Repair • Dyna Liner PVC Alloy Pipeliners 6"-36"
• BackhoeWork • Dump Truck

1035 WEST FOREST, BRIGHAM CITY, UTAH 84302
Website: www.valkoterandsons.com • Email: pearl@valkoterandsons.com

Do the SDGs Apply to Me? A Resounding YES!

By Barry Liner

A relatively new and colorful lapel pin is becoming more common throughout WEF (Alexandria, VI) events and throughout the water sector. This 25-mm (1-in) circle is decked out with 17 multi-colored pie slices. It evokes the vision of an old Trivial Pursuit game piece on steroids and packs a lot of meaning and promise for making the world a better place by 2030.

The circle and colors depicted on these pins represent the United Nations Sustainable Development Goals (SDGs). Water professionals contribute toward meeting nearly all SDGs, but focus their passion and dedication to preserving the environment and protecting public health most directly on SDG 6 – Clean Water and Sanitation.

SDGs at a Glance

In 2015, the United Nations (UN) member states adopted *the 2030 Development Agenda titled, Transforming Our World: the 2030 Agenda for Sustainable Development*.

This call-to-action for all countries was designed to work toward peace and prosperity for people and the planet. The agenda outlined 17 SDGs related to thematic areas such as water, energy, and climate; with associated targets and indicators.

SDG 6, appropriately associated with bright blue, features targets for water reuse, access, efficiency, affordability, resiliency, integrated water resources management, reduction in untreated wastewater, and enhanced research and development for water technologies. By definition, water

professionals worldwide contribute to achieving SDG 6 every day, as they have been for as long as water and wastewater professionals have existed.

WEF Actions

In 2019, WEF released a position statement in support of the objectives of the SDGs and recognizing the work that our members, Member Associations, and the water sector as a whole contribute to furthering progress. The SDGs align directly with four WEF Strategic Goals:

- Catalyze Innovation,
- Enhance the Value of Water
- Provide a Broad Range of Content
- Leverage Global Network of Water Professionals



WEF will continue to foster progress toward achievement of the SDGs by increasing water sector and public awareness of the SDGs and their importance. WEF also will promote the work that water professionals are doing to further progress toward achievement of these goals. In addition, WEF is always seeking opportunities to build upon the work currently being done and to collaborate with our Member Associations and partners worldwide; this effort also supports SDG 17 – Partnership.

The SDGs represent the evolution of the Millennium Development Goals (MDGs). At the Millennium Summit in 2000, UN Leaders adopted the United Nations Millennium Declaration, committing their nations to a new global partnership to reduce extreme poverty. This declaration set out a series of time-bound targets, with a deadline of 2015 to meet the eight MDGs focused on Developing Countries. One of the critical goals was MDG Target 7.C: Halve, by 2015, the proportion of the population without sustainable access to safe drinking water and basic sanitation. The world met the target of halving the proportion of people without access to improved sources of water, five years ahead of schedule. Between 1990 and 2015, 2.6 billion people gained access to improved drinking water sources. Worldwide 2.1 billion people have gained access to improved sanitation. Despite the impressive progress, 2.4 billion are still using unimproved sanitation facilities, including 946 million people who are still practicing open defecation.

Framing the Plan

The SDGs build on the lessons learned from the MDGs. At the heart of the 17 SDGs is an urgent call for action by all countries in a global partnership. These goals recognize that ending poverty and other deprivations must go hand-in-hand with strategies that improve health and education, reduce inequality, and spur economic growth — all while tackling climate change and working to preserve our oceans and forests.

The 17 goals also encompass 169 targets that are measured by 232 indicators. For example, SDG 6 challenges the world to “ensure availability and sustainable management of water and sanitation for all.” The eight targets identified for the water sector (see sidebar) demonstrate the full breadth and scope of the work of water professionals.

Beyond SDG 6

Water professionals are the front line in public health, the circular economy and sustainable communities. It would only make sense that water also directly affects most of the other SDGs, including:

- SDG 2 – Zero Hunger
- SDG 3 – Good Health and Well-Being
- SDG 5 – Gender Equality
- SDG 7 – Affordable and Clean Energy
- SDG 9 – Industry, Innovation, and Infrastructure
- SDG 11 – Sustainable Cities and Communities
- SDG 12 – Responsible Consumption and Production
- SDG 13 – Climate Action
- SDG 14 – Life below Water
- SDG 15 – Life on the Land

Understanding the SDGs recognizes the value, both locally and globally, that

the work that water, wastewater, and stormwater professionals already do, and will continue to do. The framework enables water, wastewater, and stormwater utilities and organizations to increase legitimacy in their relations with customers and stakeholders, provides a sense of pride to operators, engineers, regulators, managers, academics, businesspeople, and all other professionals who work in the water sector and encourages using the global perspective on water resources to facilitate watershed-based solutions on a local level.

Dr. Barry Liner is Chief Technical Officer at the Water Environment Federation and leads WEF’s Water Science and Engineering Center.



More information on all of the SDGs, including their targets and measures can be found at www.sustainabledevelopment.un.org. [D1](#)

SUSTAINABLE DEVELOPMENT GOALS

SDG 6: Clean Water and Sanitation Targets

- 6.1** – By 2030, achieve universal and equitable access to safe and affordable drinking water for all.
- 6.2** – By 2030, achieve access to adequate and equitable sanitation and hygiene for all and end open defecation, paying special attention to the needs of women and girls and those in vulnerable situations.
- 6.3** – By 2030, improve water quality by reducing pollution, eliminating dumping and minimizing release of hazardous chemicals and materials, halving the proportion of untreated wastewater and substantially increasing recycling and safe reuse globally.
- 6.4** – By 2030, substantially increase water-use efficiency across all sectors and ensure sustainable withdrawals and supply of freshwater to address water scarcity and substantially reduce the number of people suffering from water scarcity.
- 6.5** – By 2030, implement integrated water resources management at all levels, including through transboundary cooperation as appropriate.
- 6.6** – By 2020, protect and restore water-related ecosystems, including mountains, forests, wetlands, rivers, aquifers and lakes.
- 6.a** – By 2030, expand international cooperation and capacity-building support to developing countries in water- and sanitation-related activities and programmes, including water harvesting, desalination, water efficiency, wastewater treatment, recycling and reuse technologies.
- 6.b** – Support and strengthen the participation of local communities in improving water and sanitation management.

DRYCAKE

Vanderbeken Enterprises Ltd.

WWW.DRYCAKE.COM

604 535-2238

SALES@DRYCAKE.COM



DEWATERING

SCREW PRESS



DRAIMAD BAGGER



SCREENING

A SCREEN FOR EVERY FLOW

GRIT REMOVAL

SEDIVORTEX

SEDIWASH

SEDITANK

SEDIGRIT

Proudly Represented By:



Davidson Sales & Engineering
West Valley City, Utah
p. 801-977-9200 e.info@dseslc.com
www.dseslc.com

Need help in transforming remote asset data into valuable business insight?

Let's talk!

Make the most of your remote assets with complete end-to-end solutions for monitoring and controlling field operations across a widely dispersed infrastructure

Controlling cost of ownership

The installation, operation and maintenance of remote site SCADA operations is often the most significant overall long term expense factor. With scalability, flexibility and ease-of-use in mind, Schneider Electric's Telemetry and Remote SCADA Solutions are tailored to help lower this total cost of ownership.

Secure and Reliable SCADA

Safety and availability are must-have characteristics of critical infrastructure. This especially holds true when considering security for SCADA systems that monitor and control remote operations across a wide array of communications technologies. At Schneider Electric, our Telemetry and Remote SCADA Solutions incorporate solid security at all levels, from the field to the enterprise.

Minimizing risk by improving safety and regulatory compliance

Many industries are challenged with increasing requirements for operational safety, compliance with environmental regulations and the overall security of assets. Schneider Electric's Telemetry and Remote SCADA Solutions address all of these critical requirements through flexible end-to-end integration and comprehensive feature sets.

Visit www.schneider-electric.com/us

LaTech
Equipment &
Controls

As Represented by **LaTech Equipment & Controls**
UTAH • MONTANA • WYOMING • IDAHO • NEVADA
Contact: (801) 886-1145 Toll free (800) 801-3982
info@latechequipment.com www.latechequipment.com

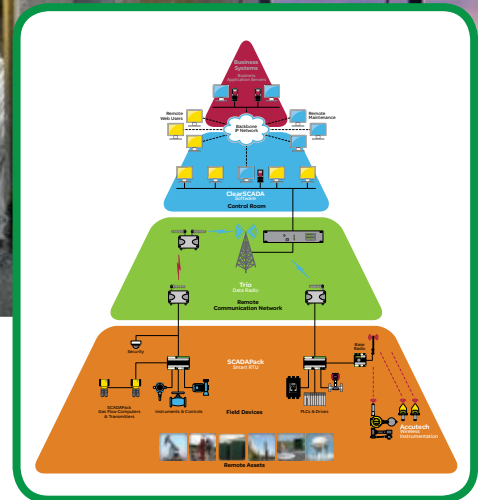

Innovation at work

SCADA Expert ClearSCADA software – Providing functions to reliably and securely manage remote SCADA assets across a wide range of communication options, with easy integration into business systems.

Trio Data Radios – Ensuring data integrity over short and long-haul distances with versatile and reliable data transmission options.

SCADAPack Smart RTUs -The monitoring and communication capabilities of a Remote Terminal Unit (RTU) combined with the processing and data-logging power of a Programmable Logic Controller (PLC).

Accutech Wireless Instrumentation – Configurable startup and failsafe conditions, enhanced diagnostics and years of maintenance free operation.

Make the most of your energySM

Schneider
Electric

Congratulations to WEAU Scholarship Recipients

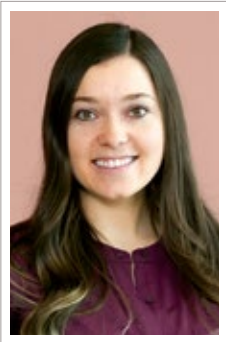

Spotlight on Jade Snyder Echard

Hi, my name is Jade Snyder Echard. I am a graduate student in Environmental Engineering at Utah State University (USU). At

USU, classes, clubs, and the amazing summer internships I've received have helped guide me to the career path that I want. These experiences helped me choose to pursue a graduate degree in Environmental Engineering, after receiving my bachelor's degree in Civil Engineering. I am passionate about water and wastewater engineering and wanted to push my career in that direction. The most valuable experience I've been a part of here at USU is the WEAU Student Chapter. I held the office of President for two years and was able to attend conferences, presentations, and activities that enriched my college experience, created networking connections, and increased my knowledge about water and wastewater. The scholarship I received from WEAU is another benefit I've received from being involved with the organization. It was a scholarship for members of WEAU working in Utah's Wastewater field. I have been a member of WEAU for four years now and worked full time for Stantec during the summer and part time when school started. I am so grateful for the scholarship and for the ability it has given me to pursue my educational goals with a lighter financial burden. I encourage everyone to not only apply for scholarships through WEAU, but to become a member and take advantage of all the amazing opportunities it provides.

"I am passionate about water and wastewater engineering and wanted to push my career in that direction."



Spotlight on Dustin Walton

Growing up, a college education was never emphasized as a goal to achieve in my life. The thought of starting toward a college degree

seemed unattainable to me, both financially and mentally (where would I find the time?) As a father of three young children, I felt that it was important for them to know that college is an important step in their education. What better way than to show them. I also hoped that this move would make me a better employee by improving my math, writing, and life skills. Beginning my college education at 40 years old was a stressful and daunting task. The WEAU scholarship that I received last year helped to alleviate a lot of that stress by lifting much of the financial burden and gave me confidence toward my goal. As I have started down this path, I have found the discipline and drive I need to complete my degree. Although a long way off, with every class I get a little bit closer to my goal.

I hope that obtaining a degree will help me advance in our industry. I work at Snyderville Basin Water Reclamation District and have been a treatment operator there for almost 14 years. I love working there and appreciate all the knowledge I have learned on the job. If there are others in the industry considering furthering their education, I would tell them that college is a challenge but nothing that can't be faced with a little drive and determination. It is never too late!

"If there are others in the industry considering furthering their education, I would tell them that college is a challenge but nothing that can't be faced with a little drive and determination."

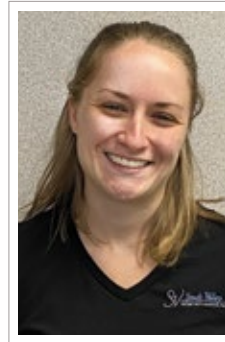

Spotlight on Nicole Hoffmeier

Hi! I'm Nicole Hoffmeier. I am a Lab Analyst at South Valley Water Reclamation Facility and I've been here for four and a

half years. Prior to this job I earned my Bachelor's degree from Brigham Young University in Environmental Science. I am currently working towards earning a Master's degree in Environmental Science and Policy from Johns Hopkins University. Outside of work and school I'm an adventurer, and enjoy traveling, hiking, and camping (unless it's cold outside or COVID-19 ruins my plans). When I can't go outside, I'm a big fan of piecing together a puzzle or reading a good book. Working full time and studying can be stressful. Earning the WEAU scholarship has helped ease some of the stress that comes with everything related to school. The classes I've taken so far have given me a greater understanding of how connected everything is; and how it all works together here on Earth. This in turn has given me a better perspective of the work I am doing and how I am contributing to the improvement of the environment. The WEAU scholarship for me has been a great opportunity to help me pursue my educational goals and continue my career in the wastewater field. [D&B](#)

"The classes I've taken so far have given me a greater understanding of how connected everything is; and how it all works together here on Earth. This in turn has given me a better perspective of the work I am doing and how I am contributing to the improvement of the environment."

STRUCTURE. & INTEGRITY.



"100 years and still climbing"

**CREWS
AVAILABLE
GLOBALLY** 



INSPECTIONS	REPAIR	TANKS
Wet	Code Updates	Elevated
Dry	Paint	Ground
ROV	Insulation	Relocation
In-Service Cleaning		Erection
		Dismantles

Wet
Dry
ROV
In-Service Cleaning

Code Updates
Paint
Insulation

Elevated
Ground
Relocation
Erection
Dismantles

If you are interested in having us as your partner, feel free to contact one of our department representatives below



NEW TANKS – Rick DiZinno
(270) 826-9000 ext. 2601

EXISTING TANKS – Patrick Heltsley
(270) 826-9000 ext. 4601

WWW.PTTG.COM

OUR WORLD IS CHANGING.
OUR PASSION REMAINS THE SAME.



WATER
OUR FOCUS
OUR BUSINESS
OUR PASSION

carollo
Engineers...Working Wonders With Water®

1.800.523.5826 | carollo.com

IT MATTERS.

WATER. It grows our children and crops.
It develops our cities and country.
It powers our industries and businesses.
It cleanses our bodies and the land.

Providing water engineering and related services to help clients achieve success.

WATER ENGINEERING | CIVIL ENGINEERING | GIS | MUNICIPAL FINANCIAL SERVICES | ASSET MANAGEMENT
INSTRUMENTATION & CONTROLS | ELECTRICAL ENGINEERING | STRUCTURAL ENGINEERING | COMMUNICATION SERVICES

THINK BIG. GO BEYOND.



Advanced Engineering and Environmental Services, Inc.
Located In: Lehi

www.ae2s.com

2019 WEAU Award Winners

WEAU Annual Awards Facility Categories

Category	Recipients
Outstanding Collections System Over 5 MGD 2019	Magna Water District
Outstanding Collections System Under 5 MGD 2019	Orem Water Reclamation Facility
Outstanding Safety Program 2019	South Valley Water Reclamation Facility
Outstanding Discharging Lagoon	Logan City
Outstanding Water Reclamation Facility Over 5 MGD 2019	Jordan Basin Water Reclamation Facility
Outstanding Water Reclamation Facility Under 5 MGD 2019	East Canyon Water Reclamation Facility
Outstanding Pretreatment Program 2019	Logan City
Outstanding Biosolids Program 2019	Orem Water Reclamation Facility
Outstanding Laboratory 2019	Jordan Basin Water Reclamation Facility Laboratory
Excellence Award	Orem Water Reclamation Facility
Excellence Award	South Valley Sewer District

WEAU Annual Awards Individual Categories

Category	Recipient	Recipients
Outstanding Collections Operator Under 5 MGD 2019	Dallas Henline	Magna Water District
Outstanding Water Reclamation Operator Over 5 MGD 2019	Joel Thompson	Jordan Basin Water Reclamation Facility
Outstanding Water Reclamation Operator Under 5 MGD 2019	Jordan Probst	Snyderville Basin Water Reclamation Facility
Outstanding Maintenance Specialist 2019	Roger Orullian	Central Valley Water Reclamation Facility
Outstanding Pretreatment Specialist 2019	Lori Gord	South Valley Water Reclamation Facility
Outstanding Supervisor 2019	Ryan Johnson	Orem Water Reclamation Facility
Outstanding Laboratory Technician 2019	Erica Keepers	Jordan Basin Water Reclamation Facility
Outstanding Young Professional 2019	Ryan Bench	Carollo Engineers, Inc.

Board Election Results

President – Chris Reilley
 President Elect – Trevor Lindley
 Vice President – Sarah Ward
 Treasurer – John Richardson
 Secretary – Chad Burrell
 Past President – Giles Demke
 Wef Delegate – Sherry Sheffield
 Wef Delegate – Clint Rogers
 PWO Representative – Tyler Barfuss
 Director- Rob Jaterka
 Director – Marianna Sochanska
 Director – Jed Jenkins
 Director – Gary Vance
 PWO Representative Elect – Daniel Watts





YSI IQ SensorNet analytical instruments were just awarded a State of Utah Cooperative Purchasing Contract.

Please contact Ambiente H2O for State Contract Pricing.

AMBIENTE H₂O INC. Wastewater & Water Treatment Specialists

Contact: Art Oakes
801.532.4812
aoakes@ambienteh2o.com
www.ambienteh2o.com

YP Quarantine Life

By Rebecca Yoo

In addition to scrolling through endless memes, the YPs have been setting the bar high during this new Quarantine Life. When asked about their new hobbies, Andrew Greco (Ovivo) responded “playing Sudoku. I found myself grinding away at these puzzles and watching/reading into different strategies.” Amanda Stoudt (BC) wasted no time in “studying for the PE (that’s not a fun hobby though)” – shall we start the debate on whether studying for the PE is fun or not?

Besides their studious hobbies, YPs have been reflecting on how essential the water and wastewater industry really is. “Whether most people realize it or not... hoarding toilet paper and bottled water is a clear indication of that.” So, thank you, WEAU members, for showing how committed, adaptable, and amazing you are through your dedication to the industry and ultimately to our communities. [DN](#)



“ Thank you, WEAU members, for showing how committed, adaptable, and amazing you are through your dedication to the industry and ultimately to our communities.



DAVIDSON
SALES & ENGINEERING

PROCESS AND ROTATING EQUIPMENT SPECIALISTS!

Proudly representing the following manufacturers!



Built for Life.



WWW.DSESLC.COM . 2441 South 3850 West . West Valley City, Utah . 84120 . 801-977-9200

FIBERGLASS FIELD EQUIPMENT SHELTERS

Ideal for the Water/Wastewater Industries



- Maintenance Free
- Superior Construction
- Easy To Install
- Low Cost Of Ownership
- Completely Customizable
- Performs In Any Environment

BUILT FOR LIFE

CREATIVE SOLUTIONS FOR YOUR FIELD EQUIPMENT PROTECTION NEEDS

Shelter Works fiberglass enclosures are strong enough to withstand any temperature, weather or corrosive environment. Our maintenance-free shelters are constructed using our exclusive Fiber-Beam™ and FiberWrap technologies and finished to the highest quality standards. They resist damage from impact, chemicals, water, and UV rays. These shelters are easy to install and come backed by our industry leading 25-year warranty.

Proudly represented by:



DAVIDSON
SALES & ENGINEERING

2441 South 3850 West, Site 'B'
West Valley City, Utah 84120
801-977-9200

www.dseslc.com



Digested News would not be possible without the advertising support of these companies and organizations. Please think of them when you require a product or service. We have endeavoured to make it easier for you to contact these suppliers by including their telephone number and, where applicable, their websites.

Company	Page Number	Telephone	Website
(AE2S) Advanced Engineering and Environmental Services, Inc.	34	801-331-8489	www.ae2s.com
Airvac - a brand of Aqseptence Group	3	574-223-3980	www.aqseptence.com
Ambiente H2O	35	801-532-4812	www.ambienteh2o.com
Aqua-Aerobic Systems, Inc.	16	815-654-2501	www.aquanereda.com
Aqua Engineering	24	801-299-1327	www.aquaeng.com
Archer Western	15	801-534-4440	www.walshgroup.com
Bowen Collins & Associates, Inc.	24	801-495-2224	www.bowencollins.com
Carollo Engineers	34	800-523-5826	www.carollo.com
Davidson Sales & Engineering	16, 31, 36, 37, 39	801-977-9200	www.dseslc.com
DRYCAKE	31	604-535-2238	www.drycake.com
Forsgren Associates, Inc.	21	801-364-4785	www.forsgren.com
Goble Sampson Associates	17	801-268-8790	www.goblesampson.com
Hidrostal	39	630-948-3355	www.hidrostalpumps.com
InfoSense, Inc.	18	877-747-3245	www.infosense.com
isiWEST	40	970-535-0571	www.isiwest.com
Lakeside Equipment Corporation	4	630-837-5640	www.lakeside-equipment.com
LaTech Equipment & Controls	32	800-801-3982	www.latechequipment.com
Mountainland Supply Company	2	801-224-6050	www.mountainlandsupply.com
Nickerson Company	18	801-973-8888	www.nicopumps.com
Penn Valley Pump Company, Inc.	26	800-311-3311	www.pennvalleypump.com
Pipeline Inspection Services, Inc.	18	208-465-3444	www.pipelineinc.us
Pittsburg Tank & Tower Group Inc.	34	270-826-9000	www.pttg.com
Shelter Works	37	800-794-8037	www.shelterworks.com
SKM Inc.	21	801-677-0011	www.skm.com
Smith & Loveless, Inc.	6, 11	800-898-9122	www.smithandloveless.com
Sunrise Engineering, Inc.	8	801-523-0100	www.sunrise-eng.com
Twin "D" Environmental Services	19	801-771-3038	www.twind.net
Val Kotter & Sons	28	435-734-9598	www.valkotterandsons.com
Waterford Systems	6, 10	801-463-9900	www.waterfordsystems.com

DIGESTED
news
Celebrating 50 Years of Clean Water

To reach Utah's water industry professionals through the *Digested News* magazine and its targeted readership, contact Kris at your earliest convenience to discuss your company's promotional plans.



Kris Fillion, Marketing Manager | 866-985-9798 | kfillion@kelman.ca



[www HidrostalPumps.com](http://www.HidrostalPumps.com)



Self Cleaning Wet-Well System

Prerostal

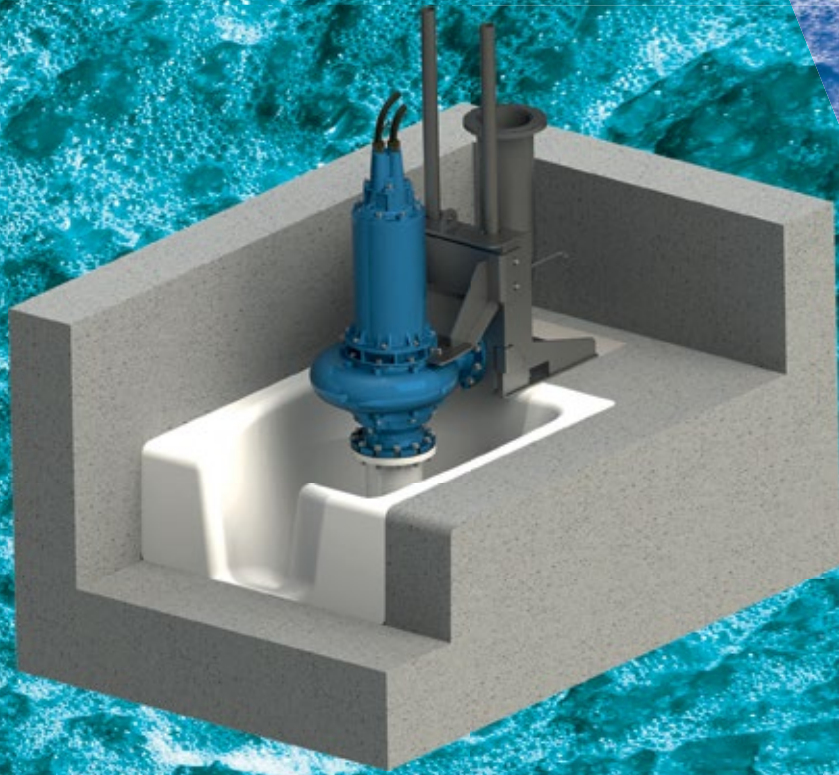

Proudly represented by:



WWW.DSESLC.COM . 2441 South 3850 West . West Valley City, Utah . 84120 . 801-977-9200

isiWEST



Jeremy Jensen

jjensen@isiwest.com www.isiwest.com

Cell 801-718-6518 Office 970-535-0571